

## Membership Survey Results

by Justin Kielty, Registrar

Sixty-five percent of our renewing members took the time to complete the survey that was included in your 2005 membership renewal. Gerard Montana, George Morten, James Aylward and I met one morning recently to compile the results and report back to the membership. We appreciate the time each of you took to provide this valuable feedback. The program committee will make every effort to respond this year and next to your suggestions.

Count	Survey Category
46	Guild-sponsored major recitals
41	Member recitals
41	Organ crawls
36	Small groups playing through/listening to new organ music
29	Guild-sponsored workshops
26	Choral reading sessions
23	Composer forums for sharing new compositions
18	Small groups reviewing new recordings/books on music
16	Guild socials
6	Other ideas
23	I would be willing to host one of the events listed above
18	I would be willing to help organize one of the events listed above

It is clear that members' preferences lean toward recitals, organ crawls and reading through new organ music. Some of the requested events have already been scheduled for this program year. As a point of fact, the composers' forums event took place on November 7 in Oakland, and on November 14 in San Francisco. Our program in January is a major recital and our program in March will be a members' recital. We hope to see many of you there, especially those of you who requested these programs. These events take a lot of work to organize and arrange, and it is rewarding to see many attendees.

It is also gratifying to see the many members who indicated a willingness to help organize events and host them. Thank you! The committee will be in touch with you to solicit your assistance as plans progress to make these events a reality. 

## SF/AGO 2005-2006 SEASON PROGRAM

2006

Sunday, January 29, 4:00 pm

Fred Swann, Organist  
Grace Cathedral, San Francisco

Monday, February 27

Members Piano, Duo Piano &  
Harpsichord Recital  
Grace Presbyterian Church, Walnut Creek  
Performers TBA

Monday, March 20, 7:30 pm

Play Something Quick  
A Session of Sharing Favorite Easy Pieces  
Ninth Church of Christ, Scientist, San Francisco

Saturday, May 20, 1:00 pm

Workshop - Body Mapping for Organists  
Dr Roberta Gary  
Location TBA

Sunday, May 21, 4:00 pm

Roberta Gary Recital  
St John's Presbyterian Church, Berkeley



### Inside this issue:

Thank You to Legion of Honor .....	2
Scotland Organ Tour .....	2
OHS Online Data Base .....	2
We NEED You! .....	4
Last Call to Las Vegas .....	4
Thompson Recital & Workshop .....	5
Donations Gone Awry .....	6
New Members Recognized .....	6
Countdown: ChicAGO .....	6
Classifieds .....	6
Events Calendar .....	7, 8

## A Big Thank You to the Legion of Honor And the Fine Arts Museums of San Francisco

by Paul W Motter

A few months ago, several members of the San Francisco Chapter of the American Guild of Organists contacted Ms Barbara Boucke, Deputy Director for Development, and Ms Sherin S Kyte, Legion Administrator, regarding an annoying problem during organ recitals at the Legion of Honor. A scraping sound, generated by the moving of chairs, together with the live acoustics of Gallery Ten where the console is located, disrupted the music and made it difficult for organists to concentrate.

Manufacturers of the chairs were contacted, and the problem was addressed by the installation of soft pads on the feet of the chairs. Organist Keith Thompson has reported to the Chapter his extreme gratitude for this improvement.

Thank you seems a lacking expression for all the concern and hard work, especially to Ms Kyte, in solving this problem. We appreciate the cooperation very much.

The Legion's historic E M Skinner pipe organ, Op. 455, was built and installed in 1924. The instrument has seven divisions with sixty-three ranks and 4,546 pipes. The console has four manuals and pedals and is one of the most elaborate examples ever built by the Skinner Organ Company. Drawknobs of ivory and ebony are fitted into a solid walnut carved case, which is in the Louis XVI style. The instrument has been maintained for over twenty-five years by Edward Millington Stout, III, Quality Pipe Organ Services.

Recitals, maintenance, and restoration, which is ongoing, is made possible through the generosity of the Joseph G Bradley, Jr. Charitable Foundation.

Concerts are every Saturday and Sunday at 4:00 p.m., and are performed by AGO members. 

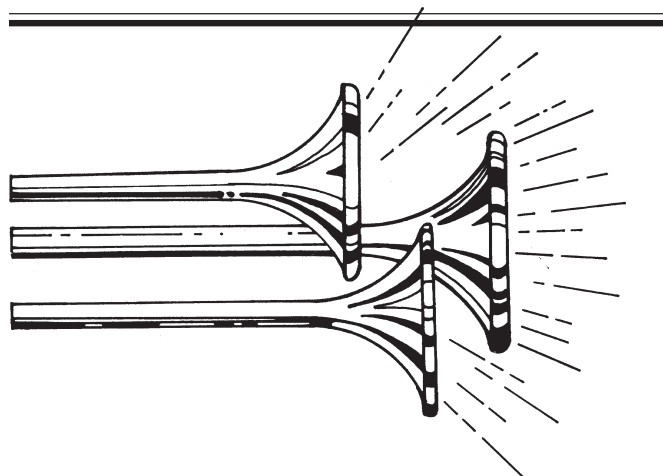

## Scotland Organ Tour, October 1–14, 2006

by Andrew Holtan

Come spend two weeks in beautiful Scotland, seeing, hearing and playing many of the outstanding instruments of the country, built by some of the world's finest organ builders—Harrison and Harrison, JW Walker & Sons, Hill Norman & Beard, Rushworth & Dreaper, Kenneth Jones and many more. We will be staying in our own private castle, with amazing countryside and comfortable accommodations.

The price, \$3,595 for AGO members and \$3,845 for non-AGO members, includes return airfare (JFK-NYC), all castle accommodations, daily breakfast, entrance fees and donations to churches, all ground transportation, tour guide services of a former cathedral organist and historical/specification information for each instrument. There will be opportunities to play many of the instruments visited, and to hear a demonstration of the organ.

Places are limited to 14 organists, to allow for as much playing time as possible at each instrument visited; non-playing guests, partners and enthusiasts are welcome, up to a total of 6 additional people. Contact Andrew Holtan at [andrew.holtan@gmail.com](mailto:andrew.holtan@gmail.com) 

---

## Organ Historical Society Announces New Online Database of Pipe Organs

from F. Anthony Thurman

The American Guild of Organists has received news of a comprehensive new source of information about the King of Instruments: the Organ Historical Society (OHS) Pipe Organ Database. The database is the most recent manifestation of a practice of cataloging pipe organs that began when the OHS was formed a half-century ago. It is quickly becoming the world's greatest single repository of organ stoplists and descriptions, providing comprehensive data for organ scholars and aficionados, alike.

The OHS Pipe Organ Database, sponsored by Birmingham–Southern College, opened to the public in May 2005. It currently documents nearly 20,000 organs located in the United States or built by North American organbuilders. The database can be accessed from the OHS home page, [www.organsociety.org](http://www.organsociety.org). Users can search for instruments based upon a variety of parameters: geographic location, builder, and date of completion. Members and friends of the AGO are encouraged to contribute information to the database by submitting additions and updates. Full participation by the organ playing and organbuilding communities will ensure that this database will become the largest and most valuable on-line organ resource in the world. 

CONGREGATION EMANU-EL

*presents*

**THE ANNUAL LUDWIG ALTMAN MEMORIAL CONCERT**

**“CREATION”**

JOSEF HAYDN

**4:00 P.M.**

**SUNDAY, DECEMBER 11, 2005**

MAIN SANCTUARY  
TEMPLE EMANU-EL  
2 LAKE STREET  
SAN FRANCISCO

*Featuring*

CANTOR ROSLYN BARAK, SOPRANO

DALE TRACY, TENOR

RICARDO HERRERA, BARITONE

THE SAN FRANCISCO STATE UNIVERSITY CHORUSES

ADMISSION IS FREE

FOR MORE INFORMATION, CONTACT JUDI LEFF AT (415) 751-2535

## We Need You!

by Gerard Montana

Many AGO chapters are reporting apathetic membership, declining membership, and declining donations. The San Francisco Chapter has all these issues, and these are signs of our need for new energy and new leadership. If you are concerned about the future of our chapter, get involved. If you spend more time complaining about what the chapter is not doing vs. what it is doing, it's time for you to stop complaining and get involved.

The Nominating Committee will begin selecting the new 2006–2007 board candidates very soon. If you are interested in running for a board position, please contact Gene Clark, 415.586.0546, or Gerard Montana, 415.621.4437. Don't be shy. Speak up and let us know of your interest in a position of leadership. If you want to nominate someone who you think would be good for a particular position, call us and we'll contact that person to determine their interest.

The open positions and duties are:

### Dean

Leads the Chapter and is responsible for all aspects of a successful concern. Selects members to serve in various roles such as: Publicity, Professional Concerns, etc.

### Sub-Dean Elect

Organizes the events and meetings for the 2006–2007 year. Serves as Sub-Dean in 2007–2008 and runs those events.

### Secretary

Takes minutes of all board meetings. Handles some correspondence.

### Auditor

Elect 2. Occasional time commitment. Reviews financial issues with Treasurer.

### Members at Large

Elect 4. These members represent the general membership and attend 4 board meetings a year. They serve in this position for 4 years.

### Special Projects

Occasional time commitment. This position works with the Special Projects committee. They review and approve submitted projects for funding.

Now is the time to do something positive for your chapter. Get involved, stay involved. Meet your colleagues and have some fun in the process. 

## Hurry! Hurry! Last Call to Las Vegas!

from Dr Frances Nobert, Region IX Councillor

It's almost here! The much-anticipated Region IX Mid-Winter Conclave in Las Vegas will open its doors on Sunday, January 8.

It is still possible to join the festivities by mailing the registration form enclosed in the brochure you received last spring. You may also find the information at the Conclave website, <[www.agoregixconclave.com](http://www.agoregixconclave.com)>. We look forward to seeing you at the Sunset Hotel and Casino between 7:00 and 9:00 p.m. on January 8.

And now for a bird's eye view of the workshops:

- ✓ *The Anatomy of an Organ-building Project*: Holger Redlich and Rolf Miehle from the Beckerath company
- ✓ *Around Bach*: Cheryl Taranto
- ✓ *Beyond Rheinberger: Violin and Organ Repertoire for Everyone*: Murray/Lohuis Duo
- ✓ *Cook's Tours of Residential Organs*: Bruce Behnke, Jane Dye, Paul Hesselink, Alice Hohenthauer
- ✓ *Discover the Organ*: Wayne Leupold
- ✓ *How Sweet the Sound: Strategies for Developing the All-Volunteer Community Chorus*: Dr Jocelyn Kaye Jensen
- ✓ *How They Played: Producing Pipedreams Live*: Michael Barone
- ✓ *Literature for Handbells and Organ*: Douglas Benton
- ✓ *Meet the Composer*: Emma Lou Diemer
- ✓ *The Organ in Contemporary Worship*: Doug Wilson
- ✓ *Preparing for the 2007 Langlais Centenary*: Ann Labounsky
- ✓ *What the AGO Can Do for You: Everything You Want to Know about Your Guild in Ninety Minutes*: Christopher Cook, Ann Labounsky, Linda Margetts, Frances Nobert, Judy Riden and James E Thomashower 

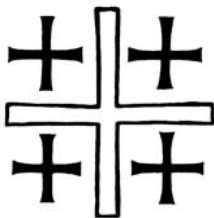

# CHORAL EVENSONG

Sunday, 4 December 2005 • 5:30 p.m.

*Music for choir, organ & string ensemble*

Aaron Copland: Two Pieces for String Quartet

John Hirten: Let my prayer arise like incense

William Byrd: Evening Canticles (Second Service)

J.S. Bach: Cantata 61, *Nun komm der Heiden Heiland*  
with organist Rodney Gehrke and soloists Baker Peebles & Ellen Kerrigan

Gabriel Fauré: Cantique de Jean Racine

Sung by the St. Francis' Choir, Robert J. Kerman, Organist & Choirmaster

*Free-will offering • Reception to follow in the Guild Hall*

St. Francis' Episcopal Church • The Reverend Bente Carter, Rector  
399 San Fernando Way (at Ocean Ave.) • San Francisco, CA 94127(415) 334-1590  
Ample street parking • Wheelchair accessible • Directions: [www.stfrancisepiscopal.org](http://www.stfrancisepiscopal.org)



## Keith Thompson Recital and Transcription Workshop

from Jim Harrod, Dean, Redwood Empire Chapter

Keith Thompson, staff organist at the California Palace of the Legion of Honor and SF/AGO member, gave a workshop "Doing Your Own Transcriptions for the Organ" and played an outstanding recital of organ transcriptions in Santa Rosa, October 15–16. Keith is a returning native to Santa Rosa and the current Sub Dean for the Redwood Empire AGO Chapter.

Keith acknowledged in his workshop that many organists have antipathy toward organ transcriptions and prefer to play only music originally written for the organ. But many of the famous composers of organ music have produced fine transcriptions: J. S. Bach, as a start. Felix Mendelssohn, Franz Liszt, Edwin H. Lemare, and W. T. Best are on the list. Transcriptions are simply music composed for one medium and transcribed to the resources of the organ. Transcriptions are not a threat to

music written for the organ originally. Good music is that which stirs the soul and cannot be limited to one instrument. The modern organ has expressive potential for a musical end which should be exploited to its fullest.

Keith's recital began with the famous Bach transcription of the Vivaldi *Concerto in a minor*, BMV 593. The program progressed from there with Keith's own transcriptions of *Lascia ch'io pianga* (Rinaldo) by G. F. Handel, Tchaikovsky's *First String Quartet* (II. Andante Sostenuto), Gounod's *Funeral March of a Marionette*, Saint-Saëns' *My Heart at Thy Sweet Voice*, and two character pieces: *Dizzy Fingers* (Zez Confrey) and *Nola* (Felix Arndt). Other transcriptions were *Finlandia* (Jean Sibelius), transcribed by H. A. Fricker, and *Pomp and Circumstance* (Sir Edward Elgar), transcribed by Edwin H. Lemare.

For more ideas on transcriptions, contact Keith at <[GASKET360@comcast.net](mailto:GASKET360@comcast.net)>

## When Donations Go Awry

Justin Kielty, Registrar

In preparing for our recent summer POE program, many members generously donated to the cause. Whether the donation was \$5 or \$500, I sent a personal letter of thanks and also listed each donor in the POE recital programs and in the newsletter.

But mistakes happen. George Emblom sent a generous check to Dean Paul Rosendall. Paul, in turn, sent the check to our treasurer for deposit, forgetting to inform me of the donation. Thus George Emblom's continuing support of the Chapter and its programs was not recognized as it should have been.

## Registrar's New Members Update

Justin Kielty, Registrar

We are most pleased to welcome the following new or returning members to the Chapter. An official welcoming reception is planned following Fred Swann's recital at Grace Cathedral on January 29, 2006. We hope that all new or returning members will be able to join us for the recital and reception. 

Peter Allen  
Jim Davis  
Tom Flesher  
Walter Knowles  
Merrilyn Krider  
Esther de Laix  
Martin Morley

Rebecca Nelson  
Shu Hwei Peng  
Orion Pitts  
Bruce and Rosalie Rasmussen  
David Shaw  
Rev. Andrew Shelton

---

## Countdown To ChicAGO

Dennis E. Northway,  
Promotions Chair, 2006 ChicAGO Convention

We hope you can join us in magnificent Chicago. We now want to tantalize you with some of the incredible musical opportunities that await you in the Windy City.

For many years acclaimed as one of the great choirs on the planet, hear the SWEDISH RADIO CHOIR in breathtaking acoustics. Enjoy mother/son, piano/organ duo JEANNINE and

ALAN MORRISON in recital in addition to our resident virtuoso DAVID SCHRADER. Many, many more exciting details to come.

One-step registration begins December 1 and early registration closes January 31. ChicAGO 2006 is offering full on line registration. Check out our website at <[www.agohq.org/2006](http://www.agohq.org/2006)> or find the forms in your upcoming issue of *The American Organist Magazine*.

See you in Chicago. 

---

## Classified Ads *Collected by Simon Berry*

This information is provided as a service to SF/AGO members and the employing institutions. Inclusion of information in this column does not imply endorsement by the SF/AGO. Send **Job Referrals** items, **Substitutes Available** notices, and **For Sale** items to: Simon Berry, 466 Duboce St, San Francisco, CA 94117; e-mail <[berrysimon@aol.com](mailto:berrysimon@aol.com)>. Next issue submission deadline is **December 10**.

### Job Referrals

#### East Bay

##### Music Director: *St Paul's Episcopal Church, Oakland.*

One Sunday morning service plus Compline once per month, weekday evening choir rehearsal. 1935 Austin cathedral organ. 8-12 person choir includes paid section leaders. We are looking for a Music Director who can bring a strong knowledge and appreciation of Anglican musical tradition and liturgy to our open and diverse community. Our 10 am Sunday service features music from Gregorian chant and the Renaissance to the present, and may include music by both Thomas A Dorsey and Thomas Tallis. 1/2 time staff position with benefits, salary range \$20-25k. Contact

The Rev. Jack Eastwood, 510.891.9516, or the church office at 510.834.4314. Application deadline: November 15, 2005.

##### Organist: *Lafayette Orinda Presbyterian Church,*

*Lafayette.* Swain & Kates, 3 manual, 44 rank pipe organ. Organist/pianist, under direction of the Director of Music and Worship. Two services on Sunday mornings and special worship services. Thursday rehearsal, 7-9 pm: 20 hours a week. Advanced degree in music desired. No salary quoted. Contact: Dr Johan P Snapper, 925.376.5462, <[johanpsnapper@comcast.net](mailto:johanpsnapper@comcast.net)>, or mail résumé to LOPC, 49 Knox Drive, Lafayette, CA.

**Concert Calendar**, *from back page*

**31 Saturday**

Robert Gurney, organ, and the San Francisco Lyric Chorus - New Year's Concert: Johann Strauss Jr., Leroy Anderson, and holiday favorites. 4pm CPLH

James Welch, New Year's Eve organ recital. Bach and more. \$10 at the door. St Mark's Episcopal Church, 600 Colorado Ave., Palo Alto. 8pm

**Looking Ahead**

**2006**

**January**

**8 Sunday**

Jared Johnson, organ. Trinity Episcopal Cathedral, Columbia, SC. Second Sunday Series. Evensong 5:30pm; Organ Recital 6:10pm SME-B

**22 Sunday**

Jeffrey Smith, organ. Three Chorales of Cesar Franck, along with two sacred duets. 3pm GC

Justin Bischof (New York), organ. 3:30pm CSMA

**28 Saturday**

Malcolm Anderson, organ. Organist for First Congregational Church in Anoka, Minnesota (suburb of Minneapolis). Music therapist with seniors in long-term care. Pacific Union College Church Sanctuary Angwin, CA (Napa Valley) 4pm

**February**

**4 Saturday**

Kimo Smith, Professor of Music and Music Department Chair at La Sierra University Church; Minister of Music at First Presbyterian Church of Hollywood. Pacific Union College Church Sanctuary Angwin, CA (Napa Valley) 4pm

**12 Sunday**

Choral: Evensong, St Francis' Choir and Instrumentalists, Robert Kerman, Organist & Choirmaster. Music of Rebecca Clarke, Vaughan Williams, and Proulx, including Handel's Chandos Anthem No. 4. St Francis' Episcopal Church, 399 San Fernando Way (at Ocean Avenue), San Francisco. Free will offering, reception to follow. More information & directions at <www.stfrancisepiscopal.org>. 5:30pm.

Lynn Trapp, organ. St Olaf Catholic Church, Minneapolis. Second Sunday Series. Evensong 5:30pm; Organ Recital 6:10pm SME-B

**18 Saturday**

Wendy Markosky, an associate professor of music at Canadian University College in Lacombe, Alberta, Canada, she teaches organ, theory, and related courses. Pacific Union College Church Sanctuary Angwin, CA (Napa Valley) 4pm

**March**

**12 Sunday**

Jonathan Dimmock, organ. All Saints' Episcopal Church, San Francisco. Second Sunday Series. Evensong 5:30pm; Organ Recital 6:10pm SME-B

**April**

**9 Sunday**

Erik Goldstrom, organ. San Francisco. Second Sunday Series. Evensong 5:30pm; Organ Recital 6:10pm SME-B

**May**

**14 Sunday**

Giorgio Parolini, organ. Basilica of St Eufemia, Milano, Italy. Second Sunday Series. Evensong 5:30pm; Organ Recital 6:10pm SME-B



SF/AGO Newsletter is published monthly, except July, by the San Francisco Chapter, American Guild of Organists. Opinions herein are those of individual contributors and do not necessarily reflect official policies of this chapter. The deadline for receipt of newsletter items is the **10th of the month** prior to publication.

Dean: Paul Alan Rosendall, 415.587.8578, <paulrosendall@aol.com>

Sub Dean: Bill Catherwood, 415.285.7214, <wcatherwood@sbcglobal.net>

Sub Dean Elect: James Awlward, 415.333.5702

Secretary: E Vaughan Jones, 650.756.6795, <evaughn318@aol.com>

Treasurer: Frances Boggiano, 415.648.1820 <francesb@gracecathedral.org>

Registrar: Justin Kiely, 415.621.5166, <jkiely@sbcglobal.net>

Chaplain: The Rev. Rosa Lee Harden, 415.515.0425, <rosalee@hardenjones.com>

Calendar Listings: Thomas A Herman, <AGOCalendar@yahoo.com>

Job Placement Listings: Simon Berry, <berrysimon@aol.com>

Obituary Listings: Donald Sears, 510.635.6869, <dsears3866@aol.com>

Newsletter Articles: George Morten, 415.695.1754, Inquiries only, *no attachments*: <gbmorten@xemaps.com>

Article submissions only, *no press releases; attachments OK*: <geomort@ix.netcom.com>

Paid Ads (Newsletter): George Morten, *attachments OK*: <pandemonium@ix.netcom.com>

Webmaster: Robert J Kerman, <rjkerman@rcn.com>

Chapter Website: <www.sfago.org>

The SF Chapter website contains a wealth of information, including past newsletters.

## Bay Area Concert Calendar *Collected by Thomas A Herman*

Events, dates, times and locations subject to change without notice. Compiled from flyers, press releases, and listings submitted by members and organizations. SF/AGO is not responsible for errors, although every effort is made to be accurate. Submission deadline for the next issue is **December 10**. Send event listings to <[AGOCalendar@yahoo.com](mailto:AGOCalendar@yahoo.com)>.

### Recurring Venues

Churches and institutions offering programs on a regular basis are assigned abbreviations to save space in our calendar listings. Abbreviations are listed alphabetically with the full name of the venue. Refer to pages 68–69 in the **2005–2006 SF/AGO Chapter Directory** for full information.

**CACK:** Church of the Advent

**CPLH:** Calif. Palace of the Legion of Honor

**CSMA:** Cath. of St Mary of the Assumption

**GC:** Grace Cathedral

**SME-B:** St Mark's Episcopal, Berkeley



### 26 Saturday

**Keith Thompson**, organ. Pops Concert, including light classics, Broadway favorites, programmatic works and highlights from organ literature. **4pm CPLH**

### 27 Sunday

**Christoph Tietze**, organ. **3:30pm CSMA**

**Keith Thompson**, organ. (Repeat: see 11/26). **4pm CPLH**

**Choral:** Schola Adventus, **Paul M Ellison**, director, **George Anton Emblom**, organ. An Advent Liturgy: Candlelight Procession with Carols for Advent Sunday. Music of Bowers-Broadbent, Britten, Palestrina, Pärt, and Wishart. Freewill offering. A festive reception follows. **6pm CACK**



### 3 Saturday

**James Welch**, organ recital, Christmas Creche Exhibit, **LDS Church**, 3865 Middlefield Rd., Palo Alto. Free. **2:30pm**

**David Hegarty**, organ. Pops concert, including light classics and favorites from Hollywood and Broadway. **4pm CPLH**

### 4 Sunday

**Vytenis Vasyliunas** (Germany), organ. **3:30pm CSMA**

**Choral:** Evensong sung by the Grace Cathedral Camerata (Ben Bachmann, director). Music of Bachmann, Morley, and Vaughan Williams. **3pm GC**

**Randall Mullin**, organ (Baltimore, MD). Works by Walton, Bolcom, Vieme, Hebble, excerpts from Cochereau's *Suite de danses*, and Duruflé's *Suite for Organ*. **4pm GC**

**Susan Jane Matthews**, organ (following 4pm Evensong). Music for Advent. Bach, Buxtehude, Demessieux, & Carter. **St Luke's Episcopal Church** <[www.stlukeslg.org](http://www.stlukeslg.org)>, Los Gatos. **4pm**

**David Hegarty**, organ. (Repeat: see 12/3). **4pm CPLH**

**Choral:** Evensong, St Francis' Choir and Instrumentalists, **Robert Kerman**, Organist & Choirmaster. Music of Aaron Copland, John Hirten, William Byrd, including Cantata 61 by JS Bach and *Cantique de Jean Racine* by Fauré. **St Francis' Episcopal Church**, 399 San Fernando Way (at Ocean Avenue), San Francisco. Free will offering, reception to follow. More information & directions at <[www.stfrancisepiscopal.org](http://www.stfrancisepiscopal.org)>. **5:30pm**

### 7 Wednesday

**Ron McKean**, organ. Music of Soler, Louis Couperin, Froberger, and improvisations. **First Presbyterian Church, Oakland**. **12:15pm**

**Choral:** Handel's *Messiah* (Part I): St Mary's Cathedral Choir, \$15/\$10; info: 415.567.2020 x213. **7:30pm CSMA**

### 10 Saturday

**Keith Thompson**, organ. Pops Concert, including light classics, Broadway favorites, programmatic works and highlights from organ literature. **4pm CPLH**

### 11 Sunday

**Choral:** Handel's *Messiah* (Part I): St Mary's Cathedral Choir. Info: 415.567.2020x213. \$15/\$10. **St Raphael's Church**, 1104 5th Ave (at A St), San Rafael. **3pm**

**Vocal: Richard Riley**, tenor. **3:30pm CSMA**

**Keith Thompson**, organ. (Repeat: see 12/10). **4pm CPLH**

**Margaret Martin Kvamme**, organ (Los Gatos). Second Sunday Series. **Evensong 5:30pm, Organ Recital 6:10pm SME-B**

### 14 Wednesday

**Ron McKean**, organ; Lenny Ott, trumpet. Noon concert, music of Clarke, Nelhybel, Persichetti, and improvisations. **First Presbyterian Church, Oakland**. **12:15pm**

### 17 Saturday

**John Karl Hirten**, organ. Works of Bach, Yon, German, Tchaikowsky, Mulet. **4pm CPLH**

### 18 Sunday

**Choral and organ:** Schola Adventus, Erik Goldstrom, guest director. Solemn Evensong and Benediction, 3pm, with music by de La Rue, Tallis and Victoria. Followed by a recital: **Erik Goldstrom** (organ). Freewill offering. A reception follows. **3pm CACK**

**Christoph Tietze**, organ. **3:30pm CSMA**

**John Karl Hirten**, organ. (Repeat: see 12/17). **4pm CPLH**

### 21 Wednesday

**Ron McKean**, organ. Noon concert: Carols from Africa, percussion and organ, electronic samplers. **First Presbyterian Church, Oakland**. **12:15pm**

### 24 Saturday

**Keith Thompson**, organ. Pops Concert, including light classics, Broadway favorites, programmatic works and high-lights from organ literature. **4pm CPLH**

### 25 Sunday

**Keith Thompson**, organ. (Repeat: see 12/24). **4pm CPLH**

► Concert Calendar, page 7